

Features

- Dual 5.5-gal. compartments for separating trash and recyclables
- Fits 13-gal. trash bags
- Fingerprint-resistant finish stays clean longer
- Hands-free operation with durable metal foot pedal
- Raised liners and locking rim for easy bag changes
- Quiet-Close™ lid closes gently and silently
- Space-saving profile fits snugly against wall or cabinets
- Hinge design protects wall from scuffs
- Removable plastic liners are easy to clean
- Cleans easily with a microfiber cloth. No need for chemicals or abrasives

Material

- Available in Stainless Steel, Black Stainless Steel, and White & Stainless Steel

Recommended Products/Accessories

K-23729 Stainless steel cleaner



Codes/Standards



None Applicable

KOHLER® Step Trash Can Ten-Year Limited Warranty

See website for detailed warranty information.

Available Colors/Finishes

Color tiles intended for reference only.

Color	Code	Description
	ST	Stainless Steel
	BST	Black Stainless
	STW	White and Stainless Steel

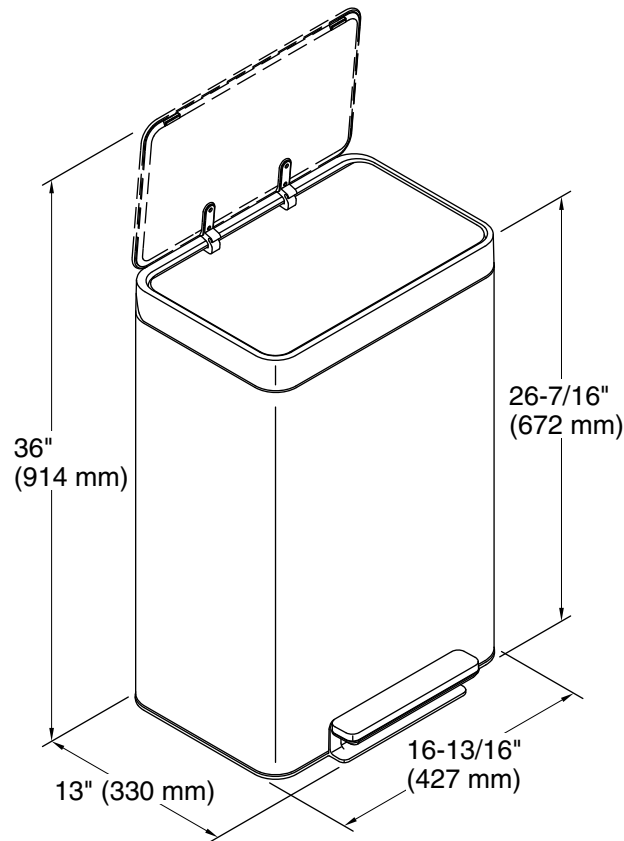

Technical Information

All product dimensions are nominal.

Material: Stainless Steel